

# INSTRUCTIONS

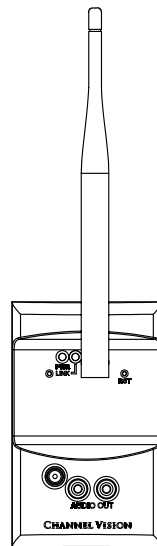
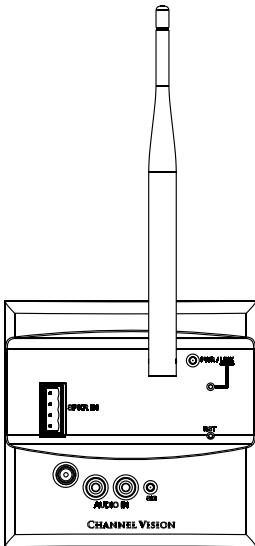

## **WA-320**

**1-to-1 Wireless Audio Transmitter**

## **WA-360**

**1-to-1 Wireless Audio Receiver**

The **WA-320** 1-to-1 Wireless Audio Transmitter and **WA-360** 1-to-1 Wireless Audio Receiver make it possible to create a distributed audio system without running wires from one room to another. The WA-320 can accept either line level or speaker level audio, making it easy to distribute signals to the rear speakers of a surround sound system. The transmitter and receiver link together on a 1-to-1 basis and can operate over 8 different transmission channels. This allows up to 8 independent stereo audio streams to be distributed in one home.

**Features:**

- Wirelessly transmits audio up to 300ft.
- Line-level and Speaker-level inputs (WA-320)
- Standard Line-level audio outputs (WA-360)
- 8 transmission channels
- Easy installation and linking

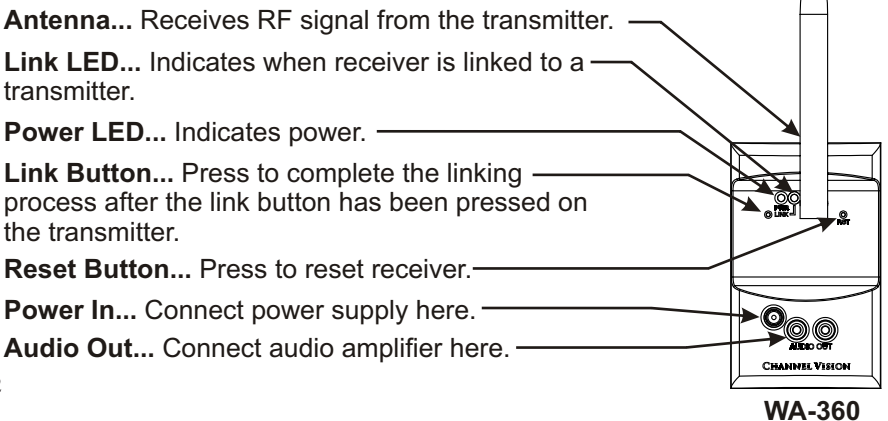
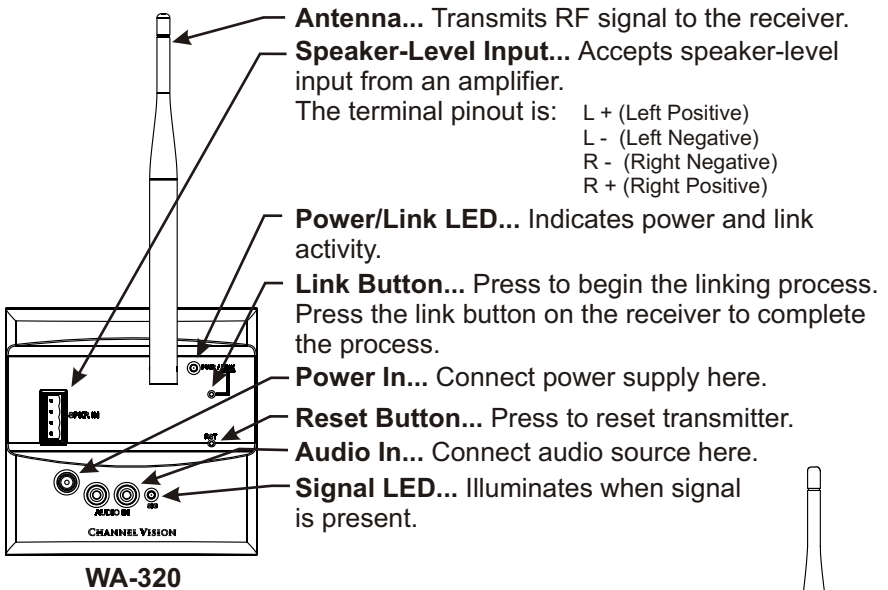

## WA-320 Rear Panel Features and Connections:

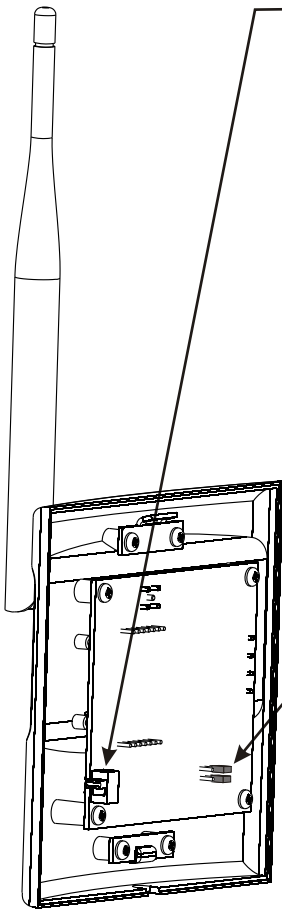

WA-320

### Input Switch...

Place in the down position when using speaker-level inputs and up position when using the line-level inputs.

### Choosing the best input for the application...

**Speaker-Level Inputs:** All home stereo amplifiers have speaker outputs which can be used to feed the speaker inputs of the WA-320 even when line-level outputs are not available. These inputs are also perfectly suited for wireless home theater speaker applications where the relative volume level of all speakers needs to be determined by the master volume control of the A/V receiver.

**Line-Level Inputs:** All standalone audio equipment and many A/V amplifiers have line-level outputs which can be connected to these inputs. These are generally "fixed" level signals which means that some kind of volume control will be needed on the output of the amplifier connected to the WA-360.

### J8 & J9 Audio Sense Jumpers...

Set to pins 1&2 to enable audio-sensing.  
Set to pins 2&3 to disable audio-sensing.

When audio-sensing is enabled, the transmitter will mute whenever there is no input audio present.

When audio-sensing is disabled, the transmitter will never mute, even if there is no audio input.

## IMPORTANT SAFETY INSTRUCTIONS

1. Read these instructions.
2. Keep these instructions for future reference.
3. Heed all warnings.
4. Follow all instructions.
5. Do not use this device near water.
6. Clean only with a dry cloth.
7. Do not block any ventilation openings. Install in accordance with these instructions.
8. Do not install near any heat sources such as radiators, heat registers, stoves, or other apparatus (including amplifiers) that produce heat.
9. This apparatus must not be exposed to dripping or splashing and no objects filled with liquids, such as vases, shall be placed on the apparatus.
10. Protect the power cord from being walked on or pinched particularly at plugs, convenience receptacles, and the point where they exit from the apparatus.
12. Unplug this apparatus during lightning storms or when unused for long periods of time.
- 13.



Warning: To reduce the risk of electric shock, do not remove the cover (or back), no user serviceable parts inside, refer servicing to qualified service personnel.

### Accessories & Complementary Products (sold separately)



**A0240...** 2-channel 40 Watt amplifier. It can be used to power a small 1-room audio system or integrated with Channel Vision's A0302 to provide supplemental power to low power distributed audio systems.

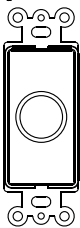

**VC-302...** Impedance Matching Volume Control  
The VC-302 is an impedance matching volume control with an IR receiver knockout. The knockout allows Channel Vision's IR-2400 to be integrated with the volume control for applications that require IR repeating. The VC-302 comes with white, ivory, and almond knobs and face plates to easily match other wall plates in the room.

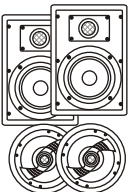

**In-wall and In-ceiling Speakers...** Channel Vision offers a full line of premium in-wall and in-ceiling speakers. These speakers are perfect for whole-house music or home theater applications.

## Linking the WA-360 to the WA-320

The WA-360 and WA-320 operate on a 1-to-1 basis and therefore they must be “Linked” to each other prior to the first use. Once linked they will maintain their paired status even if a power loss occurs. The “RST” button can be used to reset and separate a linked pair.

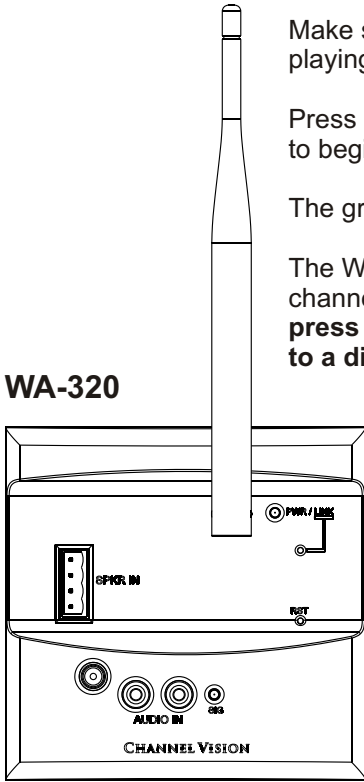

Make sure you have steady audio source playing into the WA-320.

Press and hold the Link button for 3 seconds to begin the linking process.

The green PWR/LINK LED will turn orange.

The WA-320 can broadcast on 8 different channels. **If you encounter interference, press the link button on the WA-320 to skip to a different broadcast channel.**

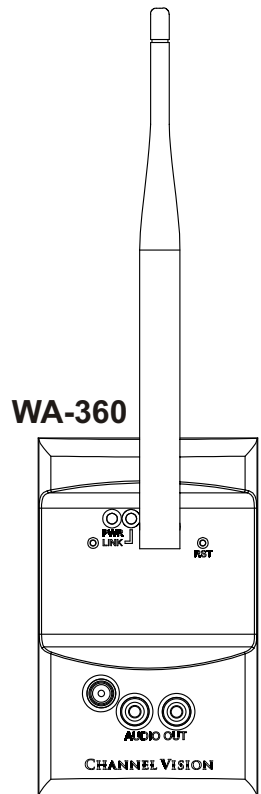

Press the link button on the receiver within 6 seconds to complete the process.

Note: The green PWR/LINK LED will blink until the receiver has been linked.

## **WA-320 Installation**

The WA-320 can be installed in the wall using a standard 2-gang junction box or low-voltage mounting ring. For surface mounted or free-standing applications, it can be installed in the back box provided. Follow the simple illustrations below.

### **In-Wall Installation**

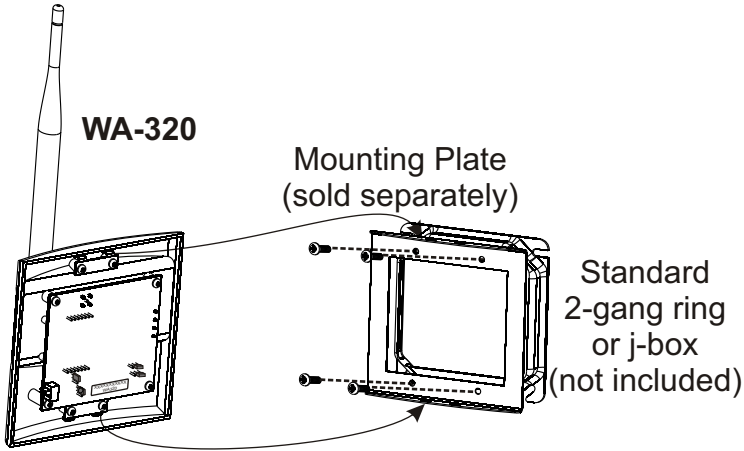

Align the tabs of the spring plates with the holes in the top and bottom flange of the mounting plate. Push on the face of the WA-320 until it snaps securely into the mounting plate.

### **Free-Standing Installation**

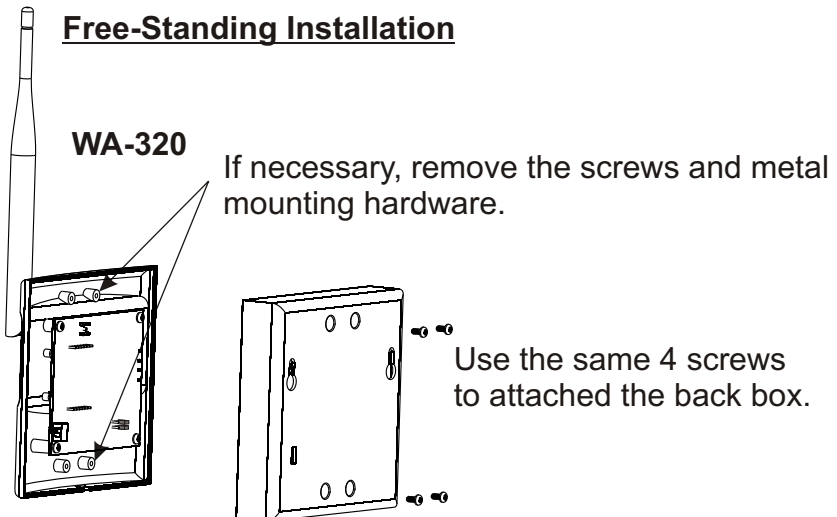

## **WA-360 Installation**

The WA-360 can be installed in the wall using a standard 1-gang junction box or low-voltage mounting ring. For surface mounted or free-standing applications, it can be installed in the back box provided. Follow the simple illustrations below.

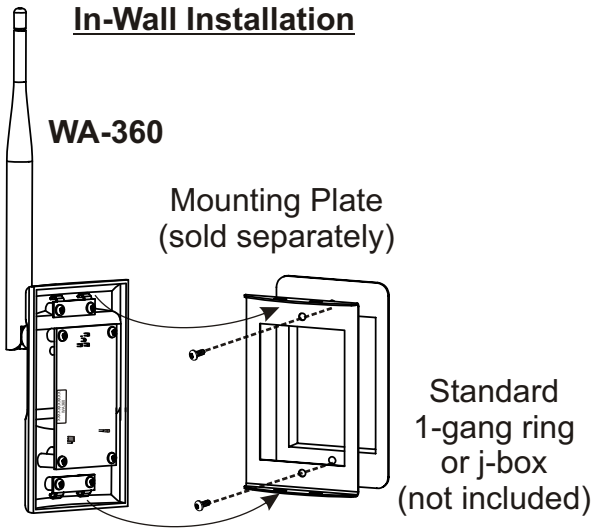

Align the tabs of the spring plates with the holes in the top and bottom flange of the mounting plate. Push on the face of the WA-360 until it snaps securely into the mounting plate.

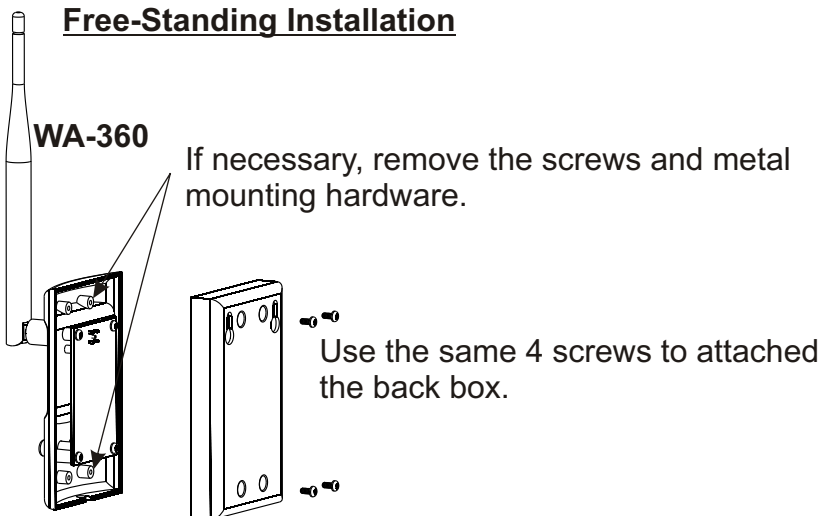

## Using the WA-320 & WA-360 in a Home Theater

The WA-320 can accept the left/right surround speaker outputs from a home theater amplifier and transmit the signal to the WA-360. The WA-360 can then output the signal to a small amplifier like the A0240 which powers the speakers. The volume level of the surround speakers will be raised and lowered by the volume control of the home theater amplifier.

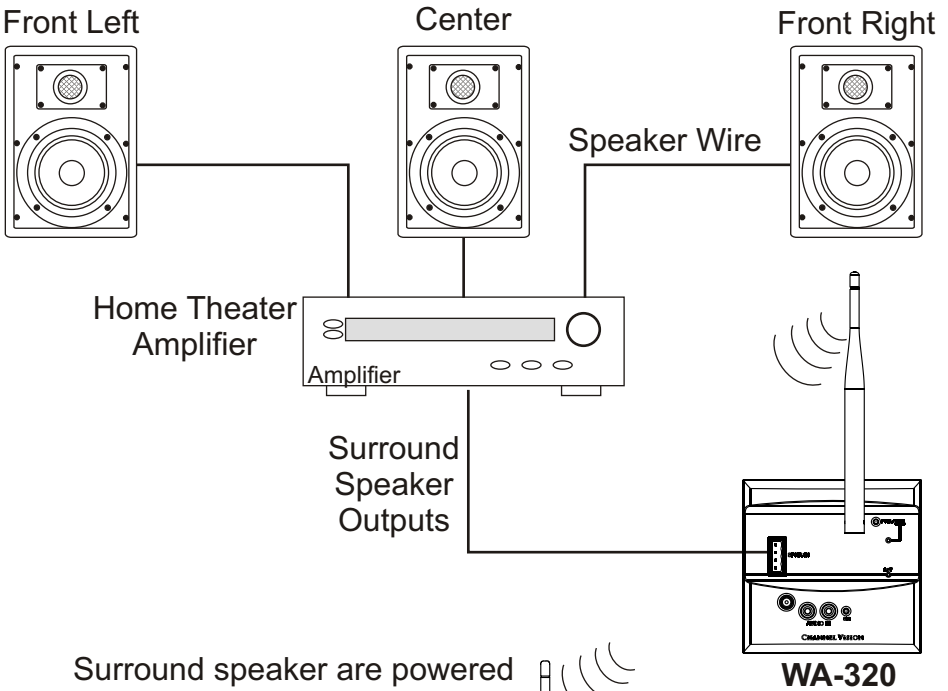

Surround speaker are powered by the A0240, but the volume is controlled by the home theater amplifier.

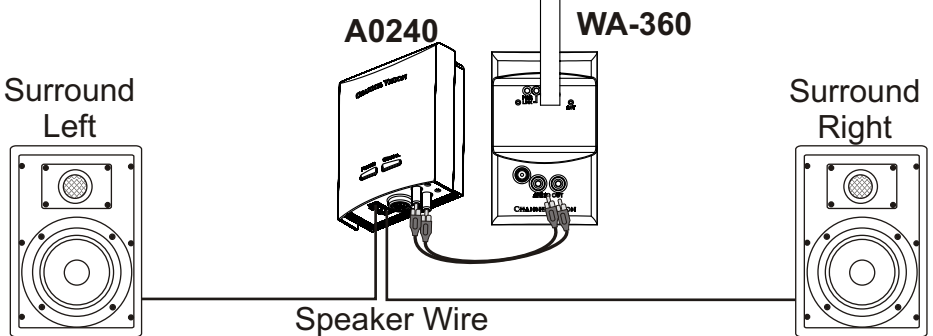



## Using the WA-320 & WA-360 for Distributed Audio

These wireless audio products make it easy to transmit audio from one room to another. Connect any standard audio component to the input connectors of the WA-320 in Room 1, and use the RCA outputs of the WA-360 to feed an amplifier in Room 2. If a fixed gain amplifier is used (such as the A0240), a volume control like the VC-302 will be needed to adjust the volume level in Room 2.

### Room 1

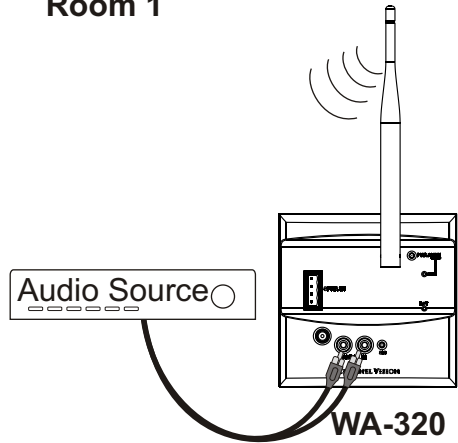

### Room 2

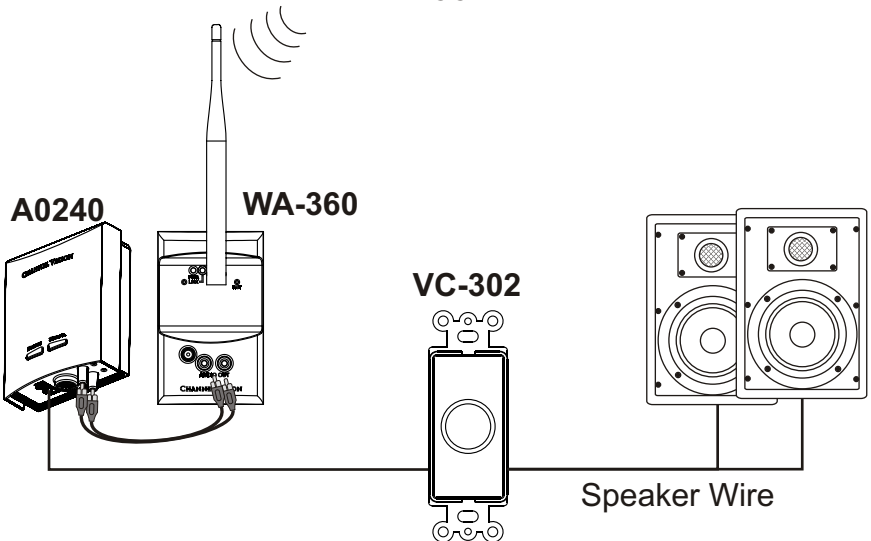

## Troubleshooting:

**Problem:** Hum in System

**Troubleshooting:** Plug all parts of the system into the same outlet to see if the hum goes away.

**Cause:** The different components in the system are connected to different electrical grounds. This forces electrical currents to find alternate paths to ground causing an audible 60Hz hum.

**Solution:** Plug products into an electrical circuit with a common ground. If it can be done safely, consider lifting the ground with a ground lifting plug.

**Problem:** Transmitter is not linking with the receiver.

**Troubleshooting:** Make sure you are linking compatible models (WA-320 with WA-360). Check if pwr/lnk LED indicator on the transmitter is turning amber and that the signal LED is lit.

**Cause:** Link button on WA-360 is not being pressed quickly enough. Review the linking procedure in this manual. Please note that a transmitter and receiver will remain paired even after being unplugged. This allows you to complete the linking process before placing the receiver in its final location.

**Solution:** Press the Link button on the WA-320 and confirm that the pwr/lnk LED turns amber. Within 6 seconds, press the Link button on the WA-360.

**Problem:** Can't link to the transmitter, or audio is cutting out.

**Troubleshooting:** Check the source, is it sending a signal? Consider setting the jumpers on the transmitter (WA-320/WA-321) to the "disable audio-sensing" position during setup procedure (see the Rear Panel Features and Connections section). This will ensure that the transmitter will not mute during pauses or very quiet passages.

**Cause:** Either there is no audio going into the transmitter, or the audio is very quiet which is causing the transmitter to mute.

**Solution:** Use a known good audio source. If you can't find any other problems, try using a different source component even if you think your audio source is OK.

**Specifications:** (typical at 25° C)

**General:**

**Storage Temperature:** -40 to +85° C  
**Operating temperature:** 0 to +55° C

**Transmit and Receive:**

**Input Voltage:** 5 VDC @ 250mA  
**THD+N:** 0.7% Max  
**S/N Ratio:** 80 dB  
**Audio Latency:** 3.8 ms  
**Operating Frequency:** 2400 MHz  
**Data Rate:** 1.152 Mbps  
**Audio Sampling Rate:** 48 kHz  
**Channels:** 8 (User Selectable)

**Transmit:**

**Transmission Power:** 8.5 dB (9.5dB Max)  
**Modulation Type:** GFSK  
**Channel Spacing:** 9 MHz  
**Max. Audio Input:** 2.6 Vpp  
**Input Impedance:** 20 kOhm  
**Max. Speaker Level In:** 100 Watts RMS

**Receive:**

**RX Sensitivity:** -85 dBm  
**Image Rejection:** 47 dBc  
**Audio Output Level:** 2.6 Vpp  
**Audio Output Impedance:** 16 Ohm  
**Frequency Response:** 20-20kHz +/- 3dB  
**Adjacent Channel Rejection:** >45 dB

Specifications subject to change without notice

The WA-320 transmitter is compliant with FCC Part 15, subpart C. The WA-360 receiver is compliant with FCC Part 15, subpart B. These limits are designed to provide reasonable protection against harmful interference in a residential installation. This equipment generates, uses and can radiate radio frequency energy and, if not installed and used in accordance with the instructions, may cause harmful interference to radio communications. However, there is no guarantee that interference will not occur in a particular installation. If this equipment does cause harmful interference to radio or television reception, which can be determined by turning the equipment off and on, the user is encouraged to try to correct the interference by one or more of the following measures:

- Reorient or relocate the receiving antenna.
- Increase the separation between the equipment and receiver.
- Connect the equipment into an outlet on a circuit different from that to which the receiver is connected.
- Consult the dealer or an experienced radio/TV technician for help.
- Modifications not expressly approved by the manufacturer could void the user's authority to operated the equipment under FCC rules.

**Channel Vision WA-320**



Tested To Comply  
With FCC Standards

FOR HOME OR OFFICE USE

**Channel Vision WA-360**



Tested To Comply  
With FCC Standards

FOR HOME OR OFFICE USE



## **2 Year Limited Warranty**

Channel Vision Technology will repair or replace any defect in material or workmanship which occurs during normal use of this product with new or rebuilt parts, free of charge in the USA, for two years from the date of original purchase. This is a no hassle warranty with no mail in warranty card needed. This warranty does not cover damages in shipment, failures caused by other products not supplied by Channel Vision Technology, or failures due to accident, misuse, abuse, or alteration of the equipment. This warranty is extended only to the original purchaser, and a purchase receipt, invoice, or other proof of original purchase date will be required before warranty repairs are provided.

Mail in service can be obtained during the warranty period by calling (800) 840-0288 toll free. A Return Authorization number must be obtained in advance and can be marked on the outside of the shipping carton.

This warranty gives you specific legal rights and you may have other rights (which vary from state to state). If a problem with this product develops during or after the warranty period, please contact Channel Vision Technology, your dealer or any factory-authorized service center.



**[www.channelvision.com](http://www.channelvision.com)**

234 Fischer Avenue, Costa Mesa, California 92626 USA

(714)424-6500 • (800)840-0288 • (714)424-6510 fax

email: [techsupport@channelvision.com](mailto:techsupport@channelvision.com)